



SAFE & SECURE SYSTEMS LTD

PROTECTING & ENHANCING YOUR PROPERTY

Underground
operator for
swing gates of up
to 3.5 m per gate
leaves



Gate operators tested
in compliance with
European
Standards on the
subject of impact
force.

Frog

**The totally hidden
operator that emphasises
your entrance**

Frog represents the synthesis of Came's design philosophy and creativity applied to swing gates. An extremely sturdy and "practically invisible" product which in no way detracts from the aesthetics of your entrance way.



Frog

230V 24V

The operator that makes the difference

Frog is Came's highly efficient operator that defies time thanks to the materials used in the foundation case and the gearmotor. A smooth, safe movement guaranteed in all working conditions, even the harshest, but which, above all needs no periodic maintenance.



Total water-tightness.
Frog's high quality standards and its IP67 protection standards from external agents keeps it always in perfect working order.

Special apertures.
Special operation levers are available and enable gate-leaf rotations of up to 180° providing better management of the space available.

EN12445 - EN12453 compliant.
The ZL19N and ZL170N control panels constantly control the gate leaves' movement allowing for safe thrust, and is EU standard compliant.



Better before.
Installing Frog is easy and setting up the foundation case enables the gate to be automated at a later date.



Easy, PATENTED release.
In the event of a blackout Frog's release mechanism is immediate. It comes in three versions for each specific need, from the practical lever to the customized key.

Durability without any compromises.
The solid foundation case is made of rustproof steel. A special stainless steel version is also available, to be installed in severe climates.

Top comfort.
Frog is also available in the 24V motor version, so that the gate can always be opened in during power outages.

Designed to withstand anything.
In designing Frog, we have chosen the best materials available, carefully studying each detail so as to obtain a no-compromise result.





The 230V electronics

Frog's new 230V electronics provides specific control and safety functions, which are standard even in the basic version. There are, however, other control boards available, for cutting-edge performance features, in terms of service and safety.

- > **Test of the active safety features**
activated before each gate operation, whether in opening or closing.
- > **Pedestrian or partial opening**
to allow opening of one gate leaf or limited opening for pedestrian access.
- > **Total control of the gate from the transmitter**
including the possibility of immediately stopping movement of the gate leaves.

24V Frog is EN TESTED



When top comfort, performance and safety are required, the Frog 24V technology enables the potential of the operator to reach the highest levels, particularly:

- > **Controlled impact forces**
Thanks to laboratory testing carried out on a door sample, 24V Frog is European standard EN12445 and EN12453 compliant, in terms of impact forces.
- > **Blackouts no more**
The Frog 24V electronics immediately act in the event of a power outage by activating the emergency function through the auxiliary batteries, to always open and close the gate (optional).
- > **Frequent passing**
The low voltage gearmotor guarantees functioning even under the most severe working conditions such as apartment blocks or industrial applications.
- > **Obstacle detection**
A special electronic circuit constantly analyses the proper functioning of the gate leaves, allowing for their total stop, or inversion of movement, when coming into contact with any obstacles.



Standard Installation

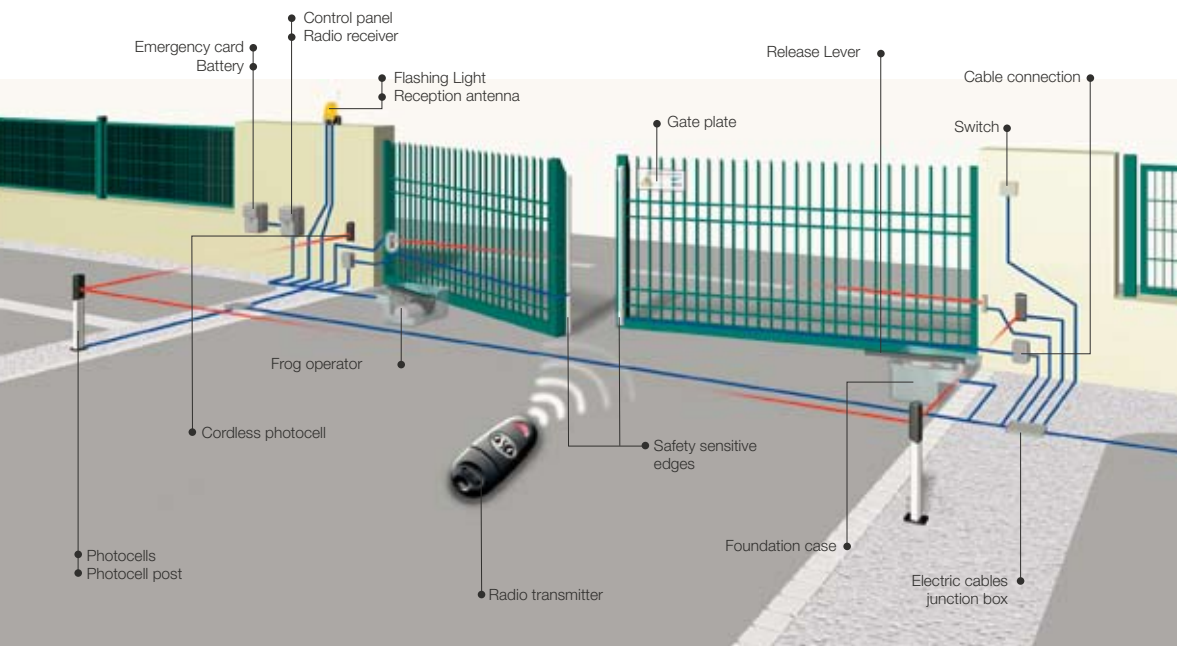

In the event a careful analysis of the automated gate's risks were to require it, the use of sensitive safety infrared or contact edges becomes indispensable.



Made in Italy



For its quality processes management Came Cancelli Automatici is ISO 9001:2000 certified, and for its environmental management it is ISO 14001 certified. Came designs and manufactures entirely in Italy.



CAME

Approved Installer

The range

230V A.C. operator

- FROG-A** Operator for residential swing gates of up to 3.5 m per gate leaves. Opening time (90°) 15 s.
- FROG-AV** Operator for residential swing gates of up to 1.3 m per gate leaves. Opening time (90°) 9 s.

230V A.C. control boards and ABS casings

- ZA4** Basic control board for 2 gate leaves fitted to take Came radio cards. (AF30-AF40 excluded).
- ZA5** Control board for 1 gate leaf fitted to take Came radio cards. (AF30-AF40 excluded).
- ZA3** Plus control board for 2 gate leaves fitted to take Came radio cards.
- ZM2** Multifunction control board for 2 gate leaves with safety device self-diagnosis, fitted to take Came radio cards.
- S4339** ABS casing with transformer. Dimensions L 197 x D 110 x H 290 mm.
- S4340** ABS casing with transformer. Dimensions L 240 x D 145 x H 320 mm.

24V D.C. operator and control panels EN12445 - EN12453 tested

- FROG-A24** Operator for residential swing gates of up to 3.5 m per gate leaves. Opening time - adjustable.
- ZL170N** Control panel for 1 gate leaf with radio decoding.
- ZL19N** Control panel for 2 gate leaves with radio decoding.

Accessories

- LB18** Card for connecting three 12V - 7Ah emergency batteries, with ABS casing.
- FROG-B** Galvanised steel foundation case.
- FROG-BI** AISI 304 stainless steel foundation case.
- A4364** Basic model with lever-key release.
- A4365** Plus model with triangular-key release.
- A4366** Top model with customized key and EURO DIN cylinder.
- A4472** Adjustable lever for mechanically stopping the gate leaf during opening.
- A4370** Heavy-duty lever for opening arcs of up to 140° (gate leaves of up to 2 m).
- FL-180** Device for 180° opening of the FROG-A and FROG-AV (gate leaves of up to 2 m).
- LOCK81** Electric lock 12V A.C. - D.C. single cylinder.
- LOCK82** Electric lock 12V A.C. - D.C. double cylinder.

Technical features

| Type | FROG-A | FROG-AV | FROG-A24 |
|--------------------------------|-------------------|-------------------|-------------------|
| Protection rating | IP67 | IP67 | IP67 |
| Control panel power supply (V) | 230 A.C. 50/60 Hz | 230 A.C. 50/60 Hz | 230 A.C. 50/60 Hz |
| Motor power supply (V) | 230 A.C. 50/60 Hz | 230 A.C. 50/60 Hz | 24 D.C. |
| Current draw (A) | 1,9 | 2,5 | 15 |
| Max power (W) | 200 | 300 | 180 |
| Opening time 90° (s) | 18 | 9 | 16 ÷ 45 |
| Duty cycle (%) | 30 | 30 | intensive use |
| Max torque (Nm) | 320 | 240 | 320 |
| Operating temperature (°C) | -20 ÷ +55 | -20 ÷ +55 | -20 ÷ +55 |

● 230V A.C. ● 24V D.C.

Limits to use

| Max gate leaf width (m) | Max gate leaf weight (Kg) |
|-------------------------|---------------------------|
| 2 | 800 |
| 2,5 | 600 |
| 3,5 | 400 |

Dimensions

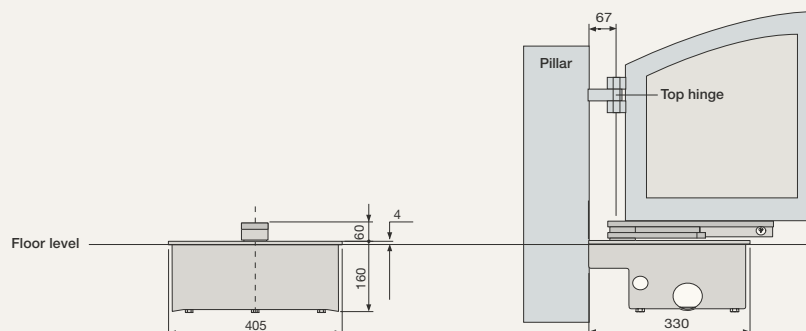

SAFE & SECURE SYSTEMS LTD
PROTECTING & ENHANCING YOUR PROPERTY

Safe & Secure Systems
Unit 5, Gracious Farm
High Street
Southill
Bedfordshire
SG18 9JB

Telephone:

01462 816571

Mobile:

07748 365912

www.safesecuresystems.com